

2360 Boswell Road
Chula Vista, CA 91914
Phone 619.216.1444
Fax 619.216.1474
E-Mail tech@explorerprocomp.com



PRO COMP SUSPENSION

Suspension Systems that Work!

Part #	Description	Qty.	Illus.	Page
90-1785	REAR CONTROL ARM DROP BRACKET, DRIVER	1	G	5
90-1790	REAR CONTROL ARM DROP BRACKET, PASSENGER	1	G	5
90-6276	HARDWARE PACK, REAR CONTROL ARM DROP BRACKET1		G	5
70-0563501800	9/16"-12 X 3.5" GR 8 HEXBOLT	2		
70-0564001800	9/16"-12 X 4" GR 8 HEXBOLT	2		
72-056100816	9/16"-12 GR 8 STOVER NUT	4		
73-05600034	9/16" SAE HARDENED WASHER	8		
70-0501251800	1/2" X 1 1/4" GR 8 HEX BOLT	2		
72-050100816	1/2" GR 8 STOVER NUT	2		
73-05000034	1/2" GR 8 FLAT WASHER	4		

Part # 51050
**2001-2003 2wd Tahoe/
Yukon/ Yukon XL/ Avalanche**
REAR INSTALLATION SUPPLEMENT FOR
51022 and 51024MX

This document contains very important information that includes warranty information and instructions for resolving problems you may encounter. Please keep it in the vehicle as a permanent record.

Rear kit installation

1. Raise the rear of the vehicle enough for the tires to clear the ground and use jack stands on the frame to support the truck. Remove the rear tires and wheels.
2. Support the differential with your floor jack and remove the OEM shock absorbers. It may be necessary to raise the differential housing slightly to facilitate their removal.
3. Completely remove the sway bar links from both ends of the sway bar. Save the fasteners.
4. Remove the OE bolts from the differential track bar at the upper track bar mount. Save this hardware.
5. Remove the brake line mount bolt at the upper front location of the vehicle gas tank. See **Illustration A**.
6. Carefully lower the differential away from the vehicle and remove the stock springs.
Important: Be very careful not to damage the brake lines! Remove mounting brackets as needed to allow the brake lines freedom of movement sufficient to avoid damage. Remember to reinstall them when done.
7. At the OE bump stop, measure from the center of the existing hole at the rear 2.800

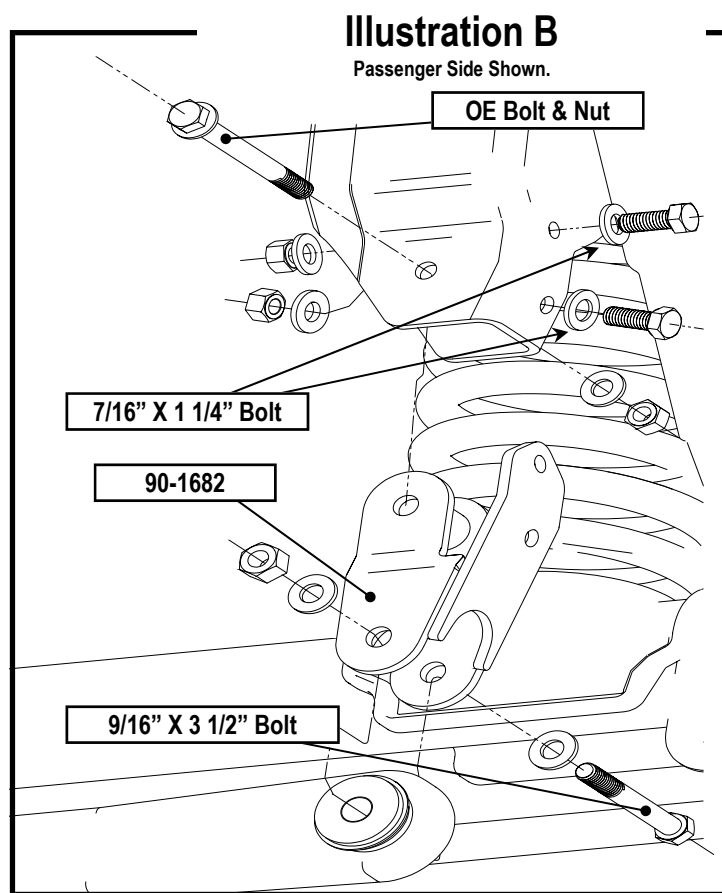
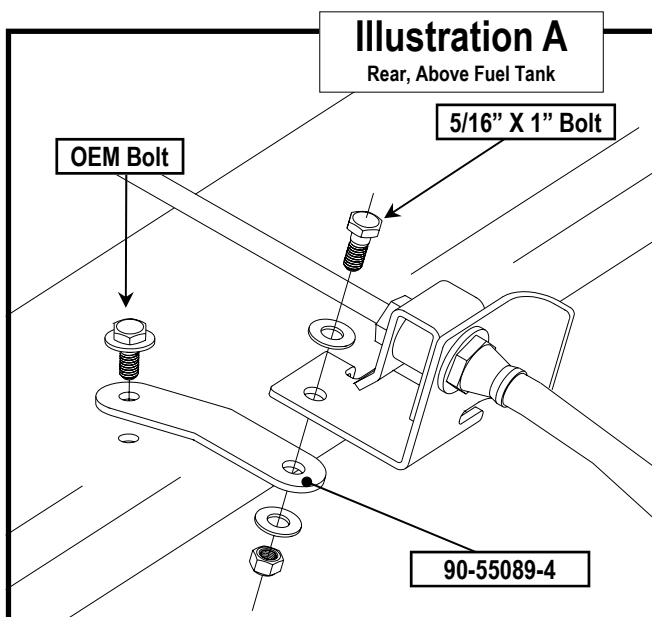

inches toward the front of the vehicle and carefully mark and center punch this location. Keep the center line between the two holes, parallel to the vehicle center line. Drill through this location with a 1/2" drill bit. See **Illustration C**.

8. Using **Illustration C** as a guide, install the bump stop extension (PN 90-2156) to the existing bump stop by first installing one 3/8" X 1" bolt and lock washer through one of the holes in the bump stop extension. Slide the nut plate (PN 90-1702) between the OE bump stop and the lower trailing arm until the back nut lines up with the hole in the OE bump stop. Take the bump stop extension with its bolt and place it on top of the pad and start the bolt into the nut plate. Rotate the nut plate to the location of the previously drilled front hole and start the second 3/8" X 1" bolt

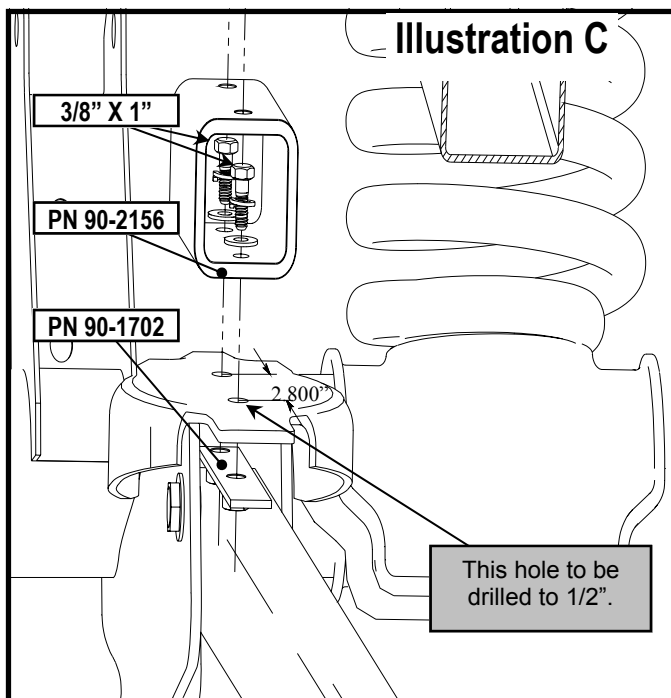

with lock washer into the remaining nut on the nut plate. Tighten these bolts to 45 ft-lbs

9. Repeat this procedure on the remaining side of the vehicle. ⚙
10. On the rear of the drivers side frame rail, loosen and disconnect the parking brake adjuster cable connector and nut. Compress the retaining fingers on the rear cables and pull the parking break cables away from the frame.

NOTE: Mark the upper and lower cables so they can be put back in the same orientation.

11. Remove the nuts and bolts attaching the upper and lower rear control arms on the driver's side of the frame. Do not remove the control arms from the passenger side .
12. Loosen the bolt attaching the lower control arm to the axle bracket. Allow the lower control arm to hang downward.
13. Attach the control arm drop bracket (DRIVER'S PN 90-1785 and PASSENGER PN 90-1790) to the frame using the original bolts. **SEE ILLUSTRATION G.**
14. Drill a 1/2" hole through the bottom of the

lower frame bracket hole and the frame. Install the 1/2" hardware from hardware pack 90-6276.

15. Tighten the 1/2" nut and bolt to 65 ft-lbs and the original bolts to 80 ft-lbs.
16. Pull the parking brake cables through the new control arm drop bracket, the top cable through the bracket and the bottom cable through the hole in the side of the bracket. Connect the parking brake cable connector and nut. Adjust parking brake tension to factory specifications.
17. Loosely attach the upper control arm to the control arm drop bracket with the 9/16"X 3.5" bolt, washer and nut from hardware pack 90-6276.

NOTE: Do not tighten the pivot bolts until the vehicle is at its new ride height.

18. Loosely attach the lower control arm to the control arm drop bracket with the 9/16"X 4" bolt, washer and nut from hardware pack 90-6276.

NOTE: Do not tighten the pivot bolts until the vehicle is at its new ride height. **SEE ILLUSTRATION F.**

19. Repeat the control arm drop bracket installation on the remaining side of the vehicle. ⚙

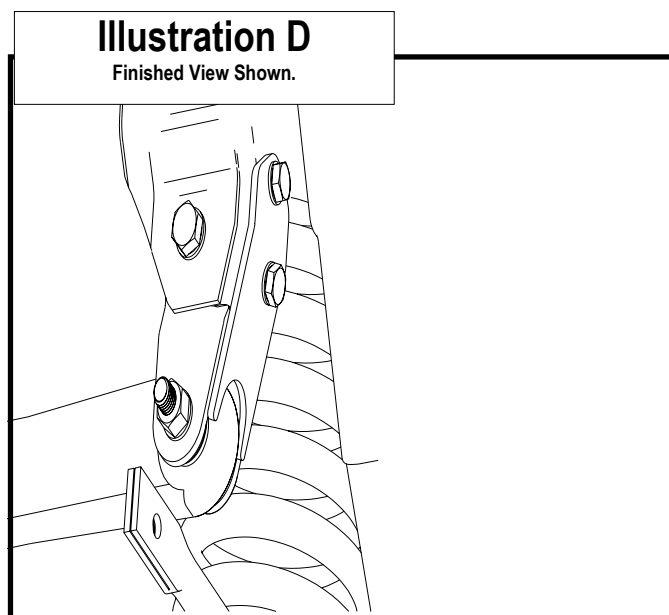

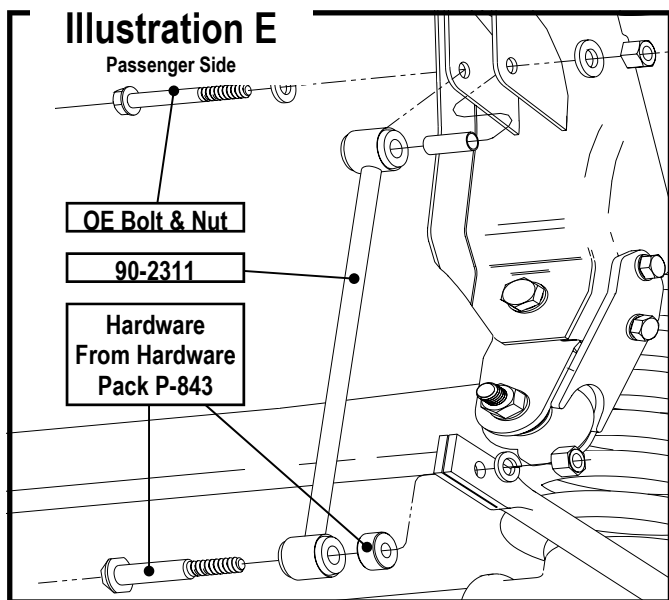

20. Compress the new spring with a coil spring compressor.
21. Continue to lower the differential until enough space exists to install the new Pro Comp springs, **PN 51021-4**.
NOTE: *If the factory spring has a rubber pad remove it and install it on to the new spring.*
22. You may have to release some slack in the differential vent hose by lightly pulling the excess down from the frame.
23. Repeat this procedure on the remaining side of the vehicle. Ⓢ
24. Raise the rear end until the new Pro Comp shock absorbers, **MX6098**, can be installed. Ensure that the new springs are seated properly.
25. Using the OE bolt, install the brake line relocation bracket (**PN 90-55089-4**) to the OE brake line mount position as shown in **Illustration A**. Bolt the OE bracket to the new relocation bracket using the **5/16" X 1"** bolt, nut, and washer provided.
26. Using **Illustration B** as a reference, install the track bar relocation adapter **PN 90-1682**. Place the adapter into the OE mount and use the OE bolt to hold it in place. On the passenger side of the adapter are two holes that are

used as drill guides for a **7/16"** drill. Drill completely through the OE mount and install the **7/16" X 1 1/4"** bolts, nuts, and washers provided. Torque these bolts to the bolt specifications in the rear of this manual.

27. Install the track bar into the newly installed adapter using the provided **9/16" X 3 1/2"** bolt, nut and washer. Torque these bolts to the bolt specifications in the rear of this manual.
28. Install the sway bar using the new end links **PN 90-2311**. Use the bushings and sleeves from **90-6235**. Use the OE bolt and nut on the top and use the hardware from pack **P-843** on the bottom. Torque these bolts to the bolt specifications in the rear of this manual. **SEE ILLUSTRATION E**.
29. Torque all fasteners.
30. Install your wheels and tires, then lower the vehicle to the ground.
31. With the vehicle on the ground and Tighten control arm bolts to OE specifications.
32. After installation is complete, double check that all nuts and bolts in the front and rear are tight. Refer to the chart at the end of this document for torque specifications. Unless

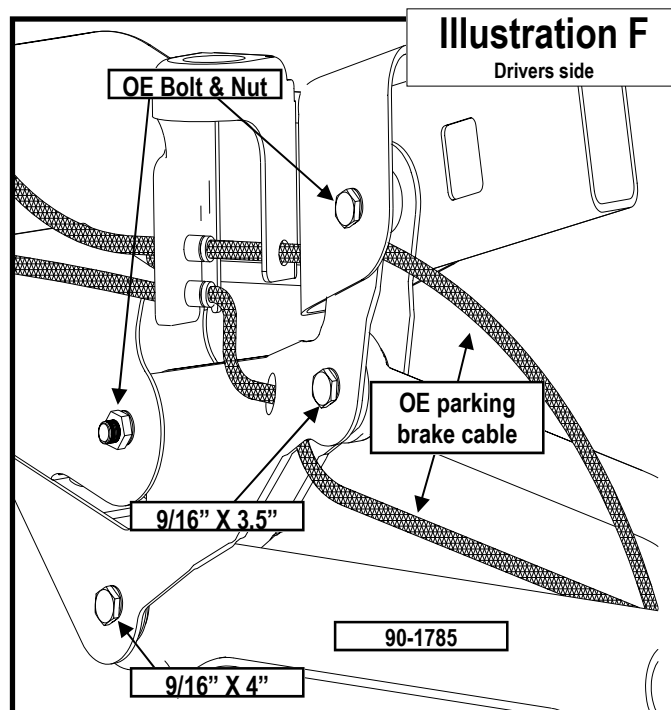

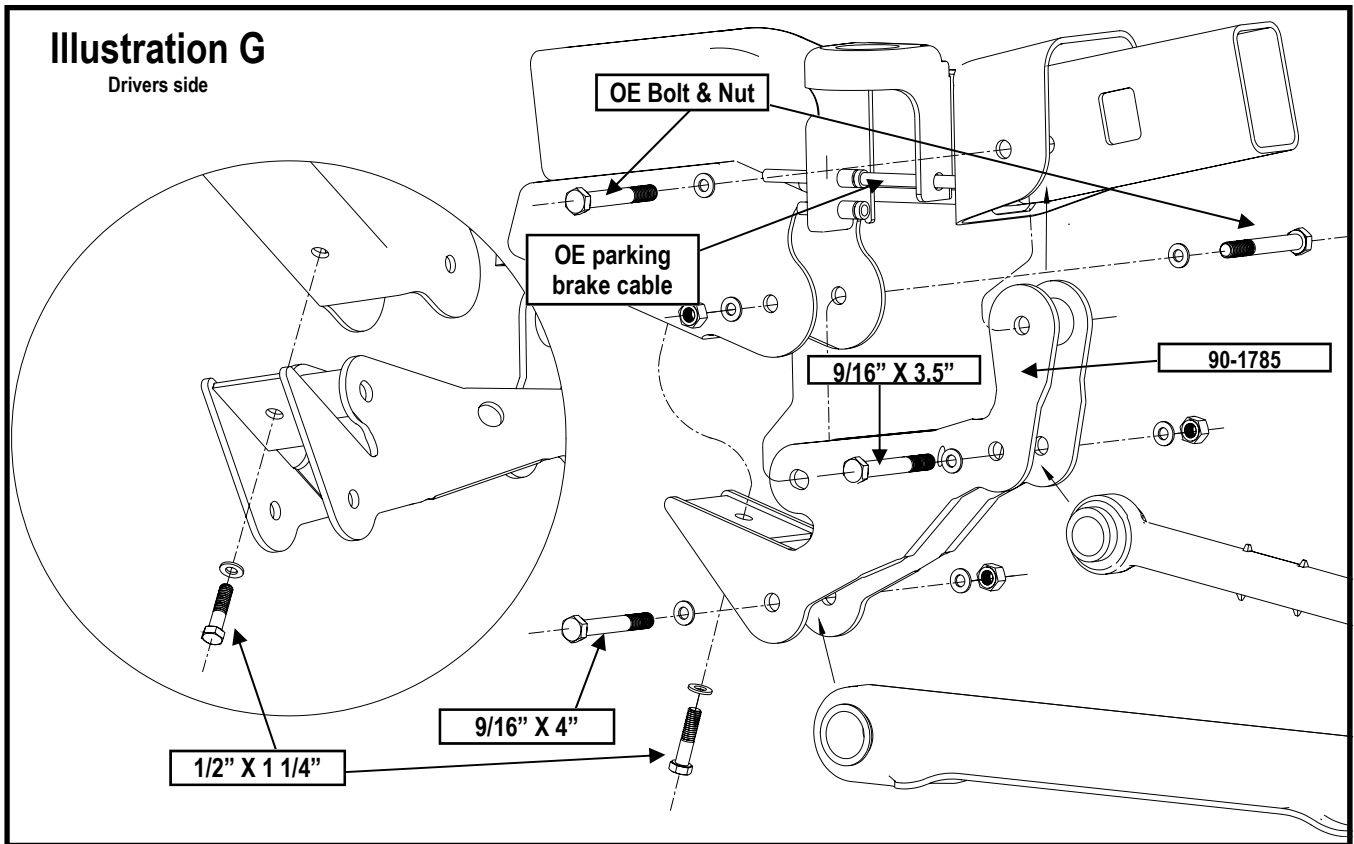

otherwise directed, use this chart for all torque specs.

33. Recheck for proper installation, then torque all newly installed hardware.
34. After 100 miles, recheck for proper torque on all newly installed hardware.
35. Recheck all hardware for tightness after each off road use. ⚠

Bolt Torque and ID						
Decimal System			Metric System			
All Torques in Ft. Lbs.						
Bolt Size	Grade 5	Grade 8	Bolt Size	Class 9.8	Class 10.9	Class 12.9
5/16	15	20	M6	5	9	12
3/8	30	45	M8	18	23	27
7/16	45	60	M10	32	45	50
1/2	65	90	M12	55	75	90
9/16	95	130	M14	85	120	145
5/8	135	175	M16	130	165	210
3/4	185	280	M18	170	240	290

1/2-13x1.75 HHCS **Grade 5 Grade 8**
(No. of Marks + 2)

D **T** **L** **X**

M12-1.25x50 HHCS

D **T** **L** **X**

G = Grade (Bolt Strength)
D = Nominal Diameter (Inches)
T = Thread Count (Threads per Inch)
L = Length (Inches)
X = Description (Hex Head Cap Screw)

P = Property Class (Bolt Strength)
D = Nominal Diameter (Millimeters)
T = Thread Pitch (Thread Width, mm)
L = Length (Millimeters)
X = Description (Hex Head Cap Screw)